

3500 lb Industrial Electric Winch Moderate Duty with Wire Rope 220/240V (1.75 Ton)

Especificaciones Técnicas

Plug	Open Leads	Pendant Control w/Quick Connector	No , Fixed
Pendant Control Buttons	2	Pendant Control Speeds	1
Capacidad de Carga	3500 lb	Capacidad 1ª Capa	3800 lb / 1750 kg
Altura de Izaje Estandar (Customizable)	Up to 328 ft / 100 m	Velocidad /min	22~34 ft / 6~10 m
Numero de Velocidades	1 Speed	Voltaje	1 Phase 220~240V 50/60Hz
Fases de entrada	1	Clase de Servicio	H2/M3/1Bm/Class B
Tipo de Motor	Electric AC	Potencia Motor	2.24 kW / 3 HP
Grado de Aislacion	F	Protección IEC Motor	IP55
Protección Tablero de Control	IP65	Control	Wired remote control
Voltaje del Control	24V	Tablero Eléctrico	Included
Cable	ø7/16 in x 328 ft ø11.1 mm x 100 m	Factor de Diseño	> 3.5:1
Tipo de Tambor	Steel	Humedad	<85%
Temperatura	-4 ~ 104° F / -20 ~ 40° C	Nivel de Ruido	85 db
Normas	ASME/ANSI B30.7,10 / AWS D14.3 / RR-W-410E / ISO 2232	Fabricado en	Taiwan
Garantía	3 Year	BD ø Diámetro Tambor	ø140 mm
FD Diámetro Flange Tambor	ø320 mm	DL Ancho Tambor	345 mm
Pendant Control Yes No	YES	IEC Pendant Control Protection	IP65
Pendant Control Emergency Stop	YES	Pendant Control total Length	7 ft

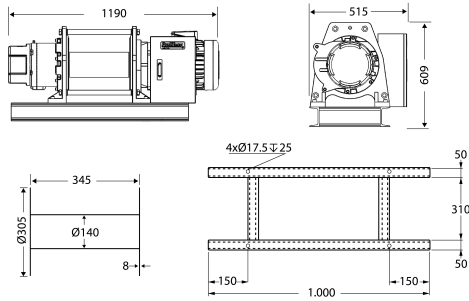

Layer / Capa	Rope on drum / Mts x Capa	Lifting x layer / Cap x Capa	Speed / Velocidad (per min)
1	59 ft / 18 m	3850 lb / 1750 kg	22.1 ft / 6.7 m
2	126 ft / 38 m	3380 lb / 1535 kg	25.2 ft / 7.7 m
3	202 ft / 62 m	3001 lb / 1367 kg	28.3 ft / 8.6 m
4	286 ft / 87 m	2710 lb / 1233 kg	31.4 ft / 9.6 m
5	378 ft / 115 m	2470 lb / 1122 kg	34.5 ft / 10.5 m

INCLUDED/INCLUIDO

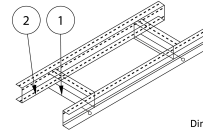
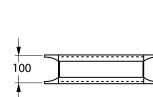

Dimensions in mm / Dimensiones en mm

Peso & Dimensiones

Detalles del Empaque

Peso Total 635 lbs / 289 Kg

A Altura Total 23.98

D Depth 20.28

W Ancho 46.85

Referential Images / Imágenes Referenciales
Specifications may change without notice / las especificaciones pueden cambiar sin previo aviso