

**1/2 ton 1100 lb 1 Speed 380V
 Electric Chain Hoist 20 ft. FEC G80
 Japan Chain H4 Duty Wireless**

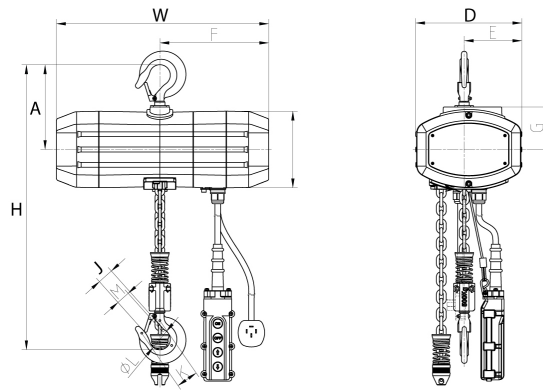

Especificaciones Técnicas

Capacidad de Carga	1100 lbs / 500 kg	Altura de Izaje Estandar (Customizable)	20 ft / 6 m
Numero de Velocidades	1 Speed	Voltaje	3 Phase 380V 50Hz
Clase de Servicio	H4/M5/2m/Class D	Freno Motor	Yes
Protección IEC Motor	IP55	Control	Wireless F21-4 and Pendant Control
Voltaje del Control	24V	Tipo de Cadena	G80 JAPAN
Dimensiones de la Cadena	6.3x19mm	Caidas de Cadena	1
Longitud de cadena	20 ft / 6 m	Humedad	<85%
Temperatura	-4 ~ 104° F / -20 ~ 40° C	Nivel de Ruido	81 dB
Normas	UL 1340 - ASME HST-1 , ASME B30.16, EN60204-32	UL File	MSXT.E528915 - Hoists
Garantía	3 Year		



Peso & Dimensiones

Detalles del Empaque

Peso Total	123 lbs / 56 Kg	W Ancho	18.1
		J Boca Gancho	1.46

Referential Images / Imágenes Referenciales
 Specifications may change without notice / las especificaciones pueden cambiar sin previo aviso