

5 Ton 2 Speed Power Trolley 380V 60HZ with Limit Switches Pendant not Included

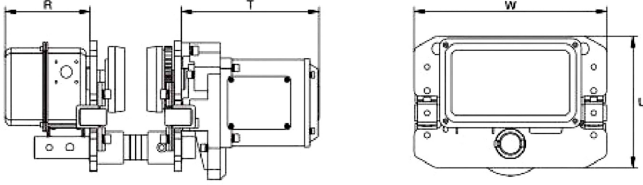

Especificaciones Técnicas

Capacidad de Carga	11000 lb / 5000 kg	Voltaje	3 Phase 380V 50Hz
Velocidad del Trolley /min	36 - 68 ft /11 - 21 m	Rango de ancho de la Viga	100-178 mm
Radio Minimo de Giro	4.9 ft / 1.5 m	Garantía	3 Year
T Motor del Carro	5.6 in / 142 mm	R Carro Ancho Caja	9 in / 231 mm



Model / Modelo	PWQE1Ti	PWQE2Ti	PWQE3Ti	PWQE5Ti	PWQE7Ti	PWQE10Ti
Dimensions / Dimensiones	W	12.4 in / 315mm	12.7 / 325mm	13.3in / 340mm	15.7 in/ 400mm	26.5 in / 670 mm
	U	8.3 in / 212mm	8.6mm / 220mm	9.8 in / 250mm	11.4 in / 291mm	-
	R	5.5 in / 142mm	5.5 in / 142mm	5.5 in / 142mm	5.5 in / 142mm	9 in / 231 mm
	T	9 in / 231mm	9 in / 231mm	9 in / 231mm	9 in / 231mm	5.6 in / 142 mm

Peso & Dimensiones

Detalles del Empaque

Peso Total	213 lbs / 97 Kg	D Depth	16.93
		W Ancho	26.38

Referential Images / Imágenes Referenciales

Specifications may change without notice / las especificaciones pueden cambiar sin previo aviso