

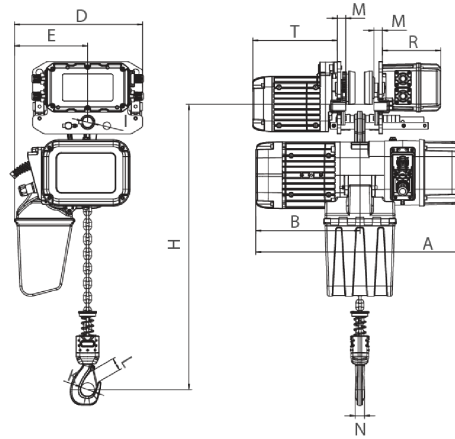

**5 ton Electric Chain Hoist w/ Power
Trolley 2 Speed 575V 3 ϕ 1/2 50/60HZ**

Especificaciones Técnicas

Capacidad de Carga	5 ton	Altura de Izaje Estandard (Customizable)	30 ft / 9 m
Velocidad /min	1 st speed : (3.1 ft @60Hz - 0.8 mt @50Hz) / 2 nd speed : (10.6 ft @60Hz - 2.7 mt @50Hz)	Numero de Velocidades	2 Speed
Voltaje	3 Phase 575v 50/60 Hz	Clase de Servicio	H4/M5/2m/Class D
Protección IEC Motor	IP55	Control	Pendant Control IP66
Voltaje del Control	24V	Tipo Transmisión / Reductor	Spur gearbox
Tipo de Cadena	G100 Nickel	Dimensiones de la Cadena	11.2 mm
Caidas de Cadena	2	Longitud de cadena	60
Humedad	20%~90%	Temperatura	-4 ~ 104° F / -20 ~ 40° C
Potencia del Trolley	750	Velocidad del Trolley /min	14.17~43.30 ft @60Hz 3.6~11 mt @50Hz
Cantidad de Velocidades	2	Rango de ancho de la Viga	3.9" to 7"
Radio Minimo de Giro	1.8	Normas	ASME HST-1 , ASME B30.16 , B30.17 , EN60204-36
Garantía	3 Year	Hoist Contactors Amps	25A
Hoist Contactor Brand	Schneider	Hoist Contactor Coil Voltage	24 V
IEC Hoist IP Protection	IP55	Pendant Control Yes No	Yes
IEC Pendant Control Protection	IP66	Pendant Control Emergency Stop	Yes
Pendant Control total Length	27 ft	Hoist Motor Power in KW	3
Hoist Motor Brake Type and DC Voltage	DC260V	Overload Protection	Overload Motor Clutch
Hour Meter	Internal Working Hour Meter	Brake rectifiers-half-wave	PWRX-BKTF-HW
Hoist Motor Insulation Grade	F	Recommended Hoist Protection Circuit Breaker AMPS and Type	Type D 20A
Optional Load Chain Brand & Country of Origin	FEC Japan	Reducer Lubrication Type	Oil
Paint Specifications	Electrostatic Sprayed Plastic (ESP) Epoxy resins, Polyester Resins, Barium, Pigments	Trolley Motor Brake Type and DC Voltage	DC260V
Trolley Motor Insulation Grade	F	Trolley Contactors Amps	40A
Trolley Contactors Brand	Schneider	Trolley Contactors Coil Voltage	24 V
Trolley Wheel Diameter	139	Trolley Wheel Material	No. 45 steel
Trolley Minimum Turn Radius	1.8 m / 5.9 ft	Trolley Beam Range	3.9" to 7"
Trolley Beam Extension Kit	up to 12"	Load Chain weight per foot [lbs]	1.83
1st Package Type	Wood Crate	2nd Package Type	Wood Crate



Rated load (t)	Type	Dimension (mm)													
		Minimum distance from the bottom of the track to the bottom hook: H	A	L	B	D	E	I	M	N	K	L	T	R	
1	PWRXT1-01	473	440	3500-5500	285	210	20	105	140						
2	PWRXT2-01	516	590		276	368	210	31	24	25	42	32	242	167	
3	PWRXT3-01	600	681		350	422	264	36	28	35	52	42	242	167	
5	PWRXT5-02	645	681		350	478	307	43	30	34	59	48	242	167	

Peso & Dimensiones

Peso Total 682 lbs / 310 Kg

Detalles del Empaque

H Altura Muerta 31.89

A Altura Total 31.89

D Depth 26.81

W Ancho 19.69

J Boca Gancho 2.36

Peso Total (sin cable o cadena) 246.46

Referential Images / Imágenes Referenciales
Specifications may change without notice / las especificaciones pueden cambiar sin previo aviso